

CEBAF CONTROL ROOM RENOVATION*

M. Spata, A. Cuffe, H. Fanning, T. Oren Jefferson Lab, Newport News, VA 23606, USA

Abstract

The Machine Control Center (MCC) at Jefferson Lab's Continuous Electron Beam Accelerator Facility (CEBAF) was constructed in the early 1990s and based on proven technology of that era. Through our experience over the last 15 years and in our planning for the facilities 12 GeV upgrade we reevaluated the control room environment to capitalize on emerging visualization and display technologies and improve on work-flow processes and ergonomic attributes. The renovation was performed in two phases during the summer of 2004, with one phase occurring during machine operations and the latter, more extensive phase, occurring during our semi-annual shutdown period. The new facility takes advantage of advances in display technology, analog and video signal management, server technology, ergonomic workspace design, lighting engineering, acoustic ceilings and raised flooring solutions to provide a marked improvement in the overall environment of machine operations.

INTRODUCTION

The MCC was initially designed and constructed as part of the original 4 GeV baseline project during the late 1980's and early 1990's. The facility is centrally located within the accelerator complex and has served as the focal point for machine operations throughout the life of the accelerator. The original control room layout consisted of a U-shaped array of 20 full-height equipment racks (figure 1) that housed analog electronics and large form-factor CRT monitors and computers. A continuous low-



Figure 1: Equipment racks and cramped workspace for operators and support staff.

depth non-adjustable worksurface was bolted to the racks to hold keyboards and mice. The MCC staff, consisting of a shift supervisor, two operators and a number of specialists, operated the accelerator controls from these rack spaces.

A separate linear array of 8 low-height equipment racks at the opposite side of the control room contained the CRT monitors and key switches for the Personnel Safety System (PSS), which was operated by one of the MCC staff to control access to the accelerator tunnel. Over the first 15 years of operating the facility we slowly replaced existing rack mounted equipment with more compact solutions and replaced much of the analog hardware with digital solutions or relocated these systems to the outlying service buildings. This reduction in effective use of the existing rack systems coupled with significant ergonomic shortfalls, and the failure of the raised-floor system prompted the redesign.

A team of Accelerator Division staff was formed to analyze emerging technologies and workplace solutions in the summer of 2003 after attendance at the Workshop for Accelerator Operation in Hayama, Japan. Over the next six months a renovation plan was developed and then approved by laboratory management for implementation over the summer of 2004.

TRANSFORMATION

The MCC renovation was an extensive undertaking touching all aspects of control room technology. These changes were precipitated by thoughtful consideration of all of the possibilities by a team of System Administrators, Operations Staff, Engineers, Technicians and Staff Scientists and then validated by a peer review process. In the end the original space was gutted from floor to ceiling and everything replaced with new systems.

Initial Preparations for Change

One would be hard-pressed to describe the technical changes to the facility without describing the overall layout to set the context. The first phase of the renovation concentrated on upgrades to the acoustic ceiling, lighting and HVAC systems as well as demolition of an interior room, called the fishbowl, which was used for support staff computing. As can be seen from the previous figures, the original space had a low ceiling populated with standard fluorescent lighting solutions, which made the space appear cramped and harshly lit. The HVAC system was part of a poorly regulated and shared equipment room system that fed cold air from below the raised flooring. The result of the first phase effort includes new acoustic tiles that offer superior sound suppression and indirect lighting solutions that provide a color rendition index

* This work was supported by DOE contract DE-AC05-84ER40150 Modification No. M175, under which the Southeastern Universities Research Association (SURA) operates the Thomas Jefferson National Accelerator Facility.

simulating sunlight. The new ducting is now contained in the ceiling and fed from an independent and well-regulated HVAC system. These changes are apparent in figure 2.

During our summer shutdown we began the second phase, which consisted of a complete removal of all remaining equipment in the first 2 of 20 days allotted for the project. All computer systems and equipment, racks, the raised flooring system, and old cables were removed in preparation for the new installation.



Figure 2: All remaining equipment removed in first 2 days. One can also see the 1st phase ceiling effort.

New Installation

We completed the renovation over the next 18 days and brought the new control room online prior to the end of our shutdown period. The new facility includes ergonomic workspaces, a large-format display system, new computer equipment, new voice and data lines, improved analog and video switching systems and many other improvements. The final result is shown in figure 3 giving a feel for the scope of work performed. I'll describe some of the technical changes that are the key elements of the renovation.



Figure 3: New space showing ergonomic workstations and main DLP display wall. Remaining equipment racks are in upper left corner.

Workstations

The project team evaluated a number of vendors over a one year period to find the best fit for operator consoles. We selected Evans Consoles™ as the most sensible overall solution for durability, aesthetics, and modularity. The new layout is depicted in figure 4 and was developed after careful consideration of people and information flow. The design team monitored the existing control room space to ascertain how it was being used and misused in this regard. We also visited a number of other control centers to gather ideas. Our new layout is a result of this research.

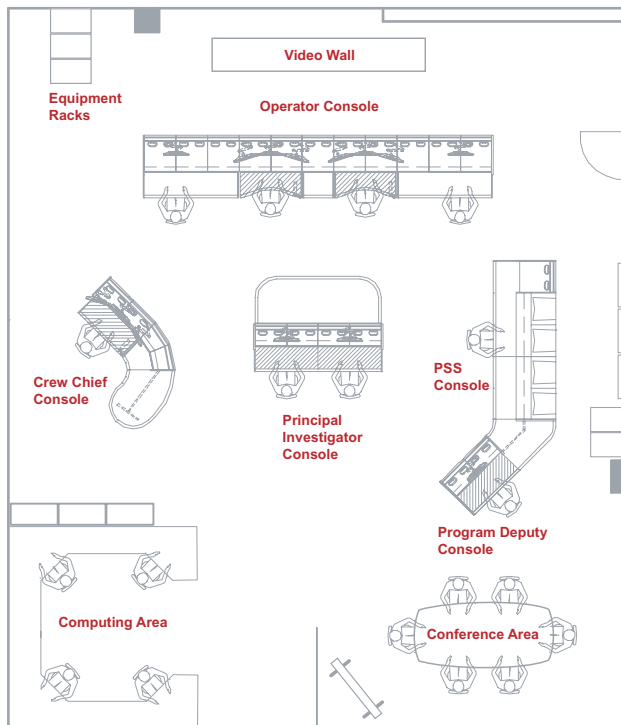

Figure 4: Renovated control room layout.

We have the crew chief or shift supervisor situated at the left side of the facility with a clear view of the space and of all displays. They are also in the best position to monitor traffic as it enters the control room. Their workspace has a single keyboard and mouse connected to a triple-headed HP B2000 workstation and an adjustable worksurface.

The main console at the top of the picture is for accelerator operators and is situated directly in front of the main video wall. Generally one finds two operators sitting at the center positions and support staff occupying the outboard stations. All workspaces have the same computer resources as the crew chief and the center positions have adjustable worksurfaces.

The center workspace is for additional support staff and has single monitors connected to HP B2000 workstations and adjustable worksurfaces. This space is typically occupied by accelerator scientists and engineering support staff.

Our PSS occupies the right hand side of the layout and is in easy reach of the accelerator operator. Three new 50" LCD and plasma displays are mounted on the right-hand wall to depict system status and video feeds from accelerator access points and are easily visible from anywhere in the control room. We have installed new switching hardware that allows for multiplexing up to 16 video displays on one 50" plasma screen. The balance of the PSS workstation contains key switch and push-button controls for operating the safety system.

Adjacent to the PSS console is our Program Deputy station. The PD is responsible for scheduling accelerator activities over a two-week period. Their workspace is positioned to provide a view of the main display wall and to allow easy access to the corner conference area which is used for planning and program development. The workspace has a single monitor connected to an HP B2000 workstation.

Video Wall

Our old array of 21" monitors has been replaced by a seamless configuration of 8-50" DLP™ rear-projection cubes from Christie Digital™. Each XGA cube has an independent projection engine providing a native resolution of 1024 x 768 pixels. With our 2x4 stacked array of 50"-diagonal displays we have a total resolution of 4096 x 1536 pixels spanning a 5 ft. tall by 13 ft. 4 in. wide display system. A schematic representation of DLP™ technology is shown in figure 5. These displays are designed for demanding control room environments and provide high brightness clear digital images of accelerator control screens, video inputs, RGB windows, and satellite feeds.

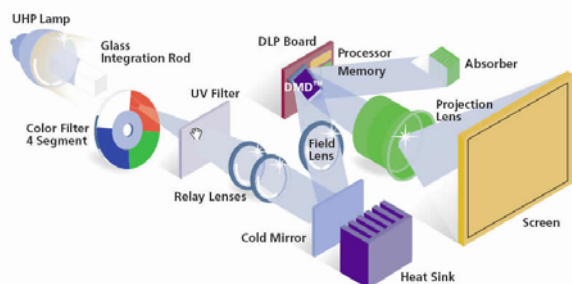

Figure 5: DLP™ display projection engine.

Display Driver

The video wall is controlled by a Jupiter™ Fusion 980 video processing system. Key specifications and aspects that contributed to the selection of this unit are:

- Supermicro X5DP8-G2, 533FSB motherboard
- Dual 2.8 GHz Xeon processors
- 2 GB of pc2100 ddr memory
- Switch Fabric™ video bus operating at 4 Gb/s
- 32 composite and 16 S-video inputs
- 4 RGB inputs
- Windows XP professional OS

- 3 scsi hard drives with 2 in a raid 1 array and 1 hot spare
- Major components are hot-swappable, including: scsi disks, power supplies, fans, display cards, switch cards, and RGB input cards
- Fully supported and well-documented API
- Motherboard similar to hardware in existing CEBAF servers
- High reliability system built by industry leader
- Developing Linux version of display drivers
- Digital dvi connection to display wall
- Expandable platform
- Save/Restore capability for screen layouts

This video processor drives all eight projection engines as one contiguous Windows™ XP desktop and allows us to bring all of our raw video, RGB data, and accelerator control screens to one large-format display.

Video Wall Environment

The CEBAF control system utilizes EPICS on a unix platform. We use Exceed™ running on a pair of HP B2600 servers to bring the X environment to the video wall's desktop. Exceed is designed to transparently integrate PC and X computing environments by providing a high-performance and feature-rich X11R6.6 compatible implementation of the X Window System. All control screens are hosted by these servers and displayed on the wall.

The accelerator utilizes video data to display beam quality information from synchrotron light images, insertable viewscreens and other devices. Presently we can display up to eight of these images at one time anywhere on the wall at arbitrary sizes. We pass all accelerator video through a switcher system to manage the signal paths.

We port RGB data to the wall from a pair of oscilloscopes and output from video digitizers for display on the wall. All 4 inputs can be displayed at the same time.

Two satellite feeds are available for display and are connected to two of the controllers S-video inputs for monitoring emergency management stations.

VNC Wall Control

The control room operator can use the local keyboard and mouse to interact with the video wall computer. In addition we have developed VNC clients to allow remote control from any of the workstations in the control room. Three clients were developed. The "control wall" application allows one to share the keyboard and mouse actions with any other user who is running "control wall". The "take wall" application provides the user with exclusive control of the wall. If one user is already using the wall their session is terminated by the new user. The "view wall" application allows any user to display the wall on their local desktop.

Metaframe Servers

Personal desktop computers have always been a part of the control room environment and are used to support general office computing and to provide access to a few of our optics modeling applications. In the old control room we used standalone units throughout the facility. In the new design we use a pair of Metaframe servers to provide access to a personal computer workspace. Standardization and maintenance were the real deciding factors. The MCC Terminal Server installation consists of two identically configured, rackmounted, Windows™ 2003 servers running Citrix™ Metaframe Presentation Server 3. Some of the key specifications are:

- Supermicro X5DP8-G2, 533FSB motherboard
- 2.8 GHZ Intel Xeon processors
- 1 GB DDR266 memory
- Two SCSI backplanes configured on separate A and B SCSI channels of onboard SCSI
- Major components are hot-swappable, including: scsi disks, power supplies, and fans
- Motherboard similar to hardware in existing display wall controller

Crosspoint Switching Networks

Analog and video data from the accelerator is routed to the control room to the three remaining equipment racks.

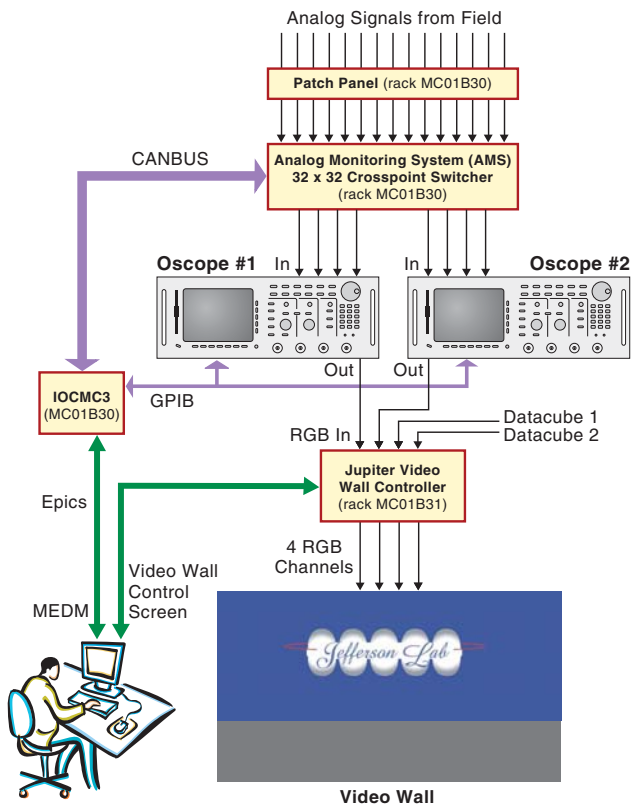

Figure 6: Analog Crosspoint Switching Network

The analog system is shown in figure 6. Field signals come into the rack system and are terminated into a patch

panel. The patched signals are connected to an Analog Crosspoint switcher which is a CANBUS controlled switching network with signal conditioning. We can take any of the inputs and connect them to one or multiple outputs. Eight dedicated lines are connected to digital oscilloscopes for analysis. Our oscilloscopes are remotely controlled through EPICS and shown on the video wall through an RGB port via the video wall computer.

Our video switching solution is shown in figure 7. We use another Crosspoint switcher to route the signals to one of the eight video connections or to a pair of digitizer systems (not shown) for analysis of the video data.

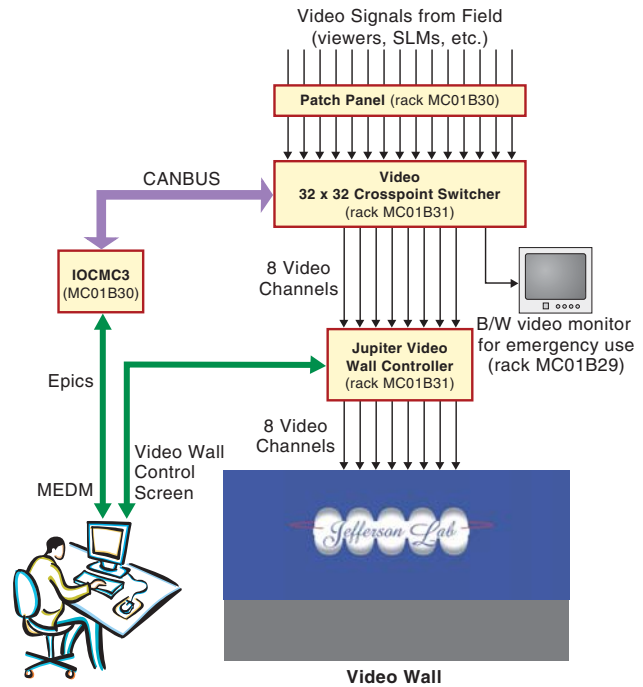

Figure 7: Video Crosspoint Switching Network

CONCLUSION

An extensive renovation of the Jefferson Lab CEBAF control room was completed in the summer of 2004. The work completely transformed the space into a state-of-the-art control room facility with all aspects of the space undergoing change. We look forward to the continued development of this work environment and in collaborating with other laboratories on future projects.

Acknowledgements

This work could not have been possible without the full support of Jefferson Lab management. We thank them for their confidence in us to perform such an extensive overhaul. We would also like to thank the many members of the Jefferson Lab staff who contributed to this effort.